



Modular Control System Installation & User Instructions

K940A – 4” Modular Control System Kit

Sargent Electrical Services Ltd.

Unit 39, Tokenspire Business Park
Beverley
East Yorkshire
HU17 0TB
United Kingdom

Office Opening Hours

Mon – Thu: 8:00am to 4:30pm
Fri: 8:00am to 12:00pm

Phone: 01482 881655
Fax: 01482 678987
E-mail: support@sargentltd.co.uk

Technical Opening Hours

Mon – Thu: 8:00am to 4:30pm
Fri: 8:00am to 12:00pm

Tech Phone: 01482 678981

Modular Control System (with EC940 Control Panel)

1 Overview

The following diagram shows the typical configuration of the modular system which provides connectivity to the ancillary components in the vehicle.

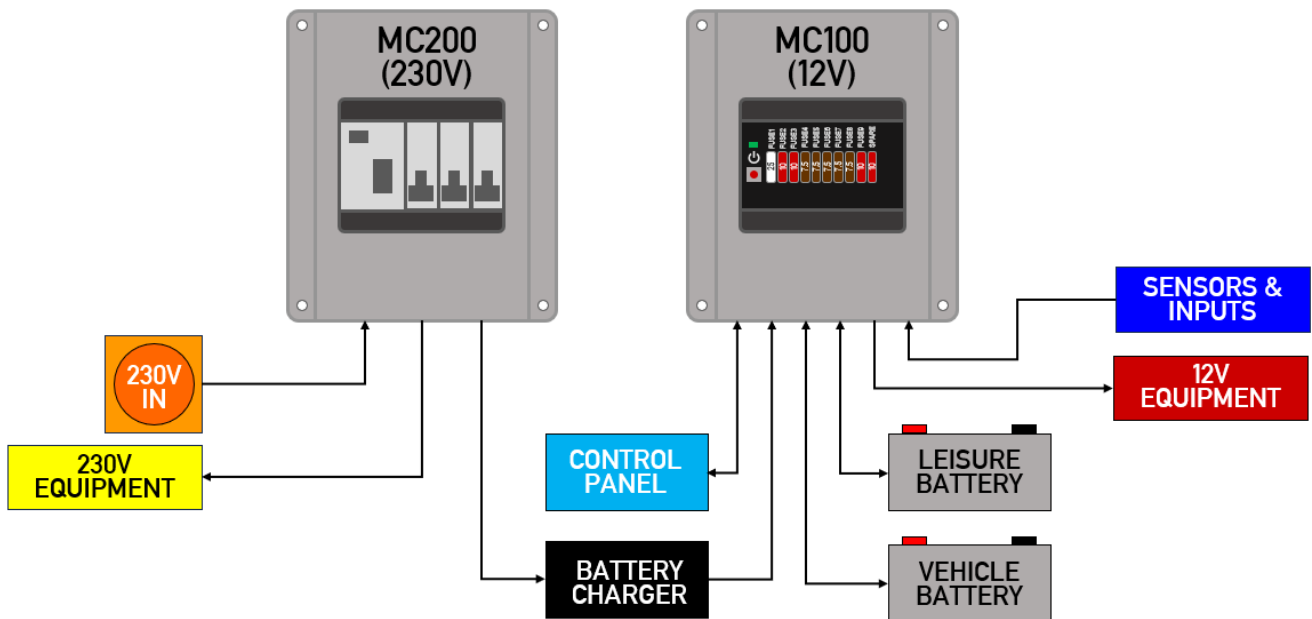

The system has a number of key components that you will need to be familiar with before attempting to use the system, these are:

- The MC100 Modular Control Unit - a 12V controller unit for monitoring, control and supply of power to battery powered equipment
- The MC200 Modular Consumer Unit - a 230V consumer unit for supplying power to mains powered electrical equipment
- The EC940 Control Panel - a remotely located user control panel used to turn circuits on and off and to display battery, water tank and other system information. This panel uses a graphical touchscreen with straightforward controls and reliable data communication to the Modular Control Unit
- The PX300 (300 Watt) Battery charger

Modular Control System (with EC940 Control Panel)

2 Installation

This section of the handbook will guide you through the installation and operation of the system. All details are correct at the time of going to press. Please also see the online version which will include any later updates or amendments.

Further technical details are contained in section 4 or in the supporting technical manual available from www.sargentltd.co.uk

For the safe operation of all electrical equipment within your Leisure Vehicle it is important that you read and fully understand these instructions. If you are unsure of any point, please contact your dealer / distributor for advice before use.

2.1 Location & Mounting

2.1.1 12V & 230V Power Supply Units

Choose a location for the EC100 & EC200 units which ensures convenient access to the protective fuses, RCD and MCB's. The units can be either be mounted in separate locations or fixed together into one installation using the central mounting bracket (see below). Mount the units vertically or horizontally and fix in position using the four fixing holes provided.

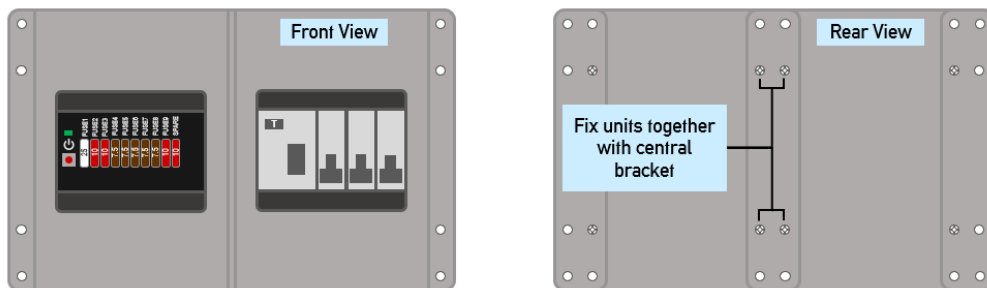

2.1.2 Control Panel

Choose a suitable location where the EC940 display can be easily viewed, then cut an aperture for fitting (see section 5.1 for size).

Connect the 6-way communication cable into either connector on rear of panel, then run back to the MC100 Modular Control Unit and attach to connector e1 (see section 5.4). Avoid running cable alongside mains or ignition circuits to reduce the possibility of interference.

Choose a suitable location for the internal temperature / humidity sensor within 400mm of the control panel, then cut an aperture for fitting (see section 5.1 for size).

Push fit the sensor into position, then connect the 3-way temperature / humidity sensor cable to rear of panel.

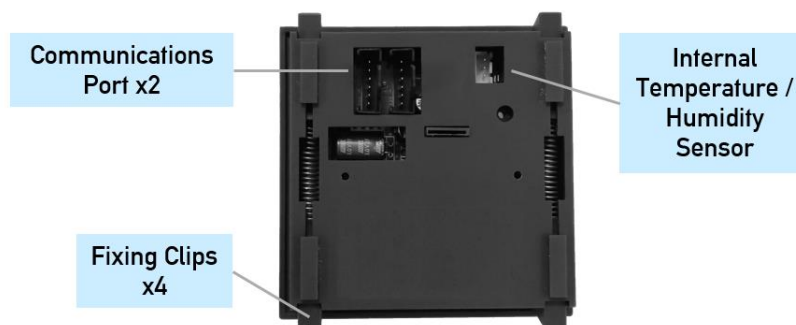

To fix the panel in position, compress the four spring loaded clips then push into position until flush with the mounting surface, no fixing screws are required.

2.1.3 Battery Charger

Choose a location for the charger which will allow airflow over the unit to provide cooling. For example, do not mount the charger in a sealed enclosure which may restrict air flow into the cooling vents. For optimum cooling mount the unit vertically and fix in position using the four fixing holes provided.

Modular Control System

(with EC940 Control Panel)

2.2 Power Wiring

WARNING

This equipment must be installed by a competent person or qualified electrician. Install in accordance with all national and local electrical wiring regulations and codes

The Modular System kit is provided with a number of pre-wired harnesses for 12V and 230V power connections. These should be cut to length where required to suit your application. The 230V mains harnesses are terminated with 3-way plugs to ensure safety during installation, these can be removed when hard wiring to appliances.

Installation wiring diagrams are provided for reference and cover motorhome and caravan installations (see Section 5.6 onwards). You should use wiring of an appropriate cross-sectional area to suit the circuit design. 230V and 12V wiring should be run separately and never clipped or tied together. All mains 230V wiring should be installed by a competent person and must meet the requirements of BS7671 (IEE Wiring Regulations, Requirements for Electrical Installations) and should be tested before use.

2.2.1 230V Wiring

a) 230V Input

Plug 3-way input cable (orange cable) into the MC200 unit, then route this cable to the rear of mains inlet socket (not supplied) and attach Live, Neutral & Earth connections. This cable must not be joined or extended, the earth within the cable must be one continuous piece from the inlet to the MC200 unit.

b) 230V Outputs

3 x 230V output harnesses are included with the kit. Plug each 3-way output cable into matching connectors on the MC200 (Outputs 1 - 3), then route around to the mains appliances, clipping the cable at suitable intervals.

Output 4 is turned on / off by the green switch on top of the unit and is reserved for the AC-DC battery charger (see section 3.2 for more information)

Output 1 is turned on / off by the amber switch on the top of the unit. This can be used to isolate, for instance, the supply to the heating system.

c) Earth Bond

Connect a 4mm earth bond cable to the earth stud provided on the chassis of the MC200 unit, run cable to the vehicle chassis and then gas pipe (if fitted). The connection to the chassis must include a safety warning label to meet BS7671 requirements. Never connect 12V negative / earth cables to the same bolt.

2.2.2 12V Wiring

The 12V output wiring comprises a 16-way connector and 8 pairs of output cables. These cables should be inserted into the 16-way connector to suit your installation wiring and routing requirements, whilst referring to the following diagrams:

For Motorhomes – see section 5.6

For Caravans – see section 5.7 & 5.8

2.2.3 12V Fridge Connections

Two types of fridges are generally available for use in caravans and motorhomes. Depending on which type is being used will determine the best position to connect 12V power from the MC100 unit.

a) Absorption

Also known as 3-way fridges, this type can be powered from a 12V Battery, 230V Mains or LPG gas. They are more suitable for prolonged use away from a mains supply and are generally fitted by manufacturers. As they require a large amount of power when operating from a 12V supply (typically up to 15 Amps) it is recommended they are powered from the vehicle battery only whilst the engine is running.

b) Compressor

This type can be powered from a 12V Battery and sometimes 230V Mains. They are more suitable for DIY fitment in smaller vehicles such as camper vans and require less power when operating from a 12V supply (typically up to 5 Amps). For this reason, they can be connected to the switched permanent output of the MC100

Modular Control System (with EC940 Control Panel)

(see diagram in section 5.6 & 5.7). This output is ON when the unit is turned on and OFF when the unit is shutdown, and therefore can act as an isolator for the fridge.

they can be connected directly to the leisure battery (via a fuse), so they can be used whilst driving or stationary.

2.2.4 Split Charge Relay

The MC100 includes a split charge relay to enable charging of the leisure battery from the vehicle supply whilst the engine is running. To enable this please ensure an 'engine running' (D+) signal is connected to Pin3 on the INPUT connector of the MC100 and a negative / D- signal connected to Pin2 on the INPUT connector.

Note:- If a D+ connection is not available then other methods of detecting the engine running are available. For further information please contact Technical Support (see section 4.7)

2.2.5 EMC Isolation Relay

The MC100 also includes an EMC isolation relay which switches off 12V equipment whilst the engine is running. This is triggered by the D+ signal (as mentioned above). It is a legal requirement to isolate equipment that is not approved for use whilst the vehicle is in motion. This ensures such items as an oven igniter cannot interrupt or affect vehicle systems.

2.3 Electrical Accessories Wiring

There are a number of accessories supplied with the standard modular system kit and others are available as optional upgrades via the CANBus interface. Below is an example overview of the accessories which may be added to the system. Note: For connecting multiple accessories, a CANBus splitter will be required to extend the number of CANBus ports available.

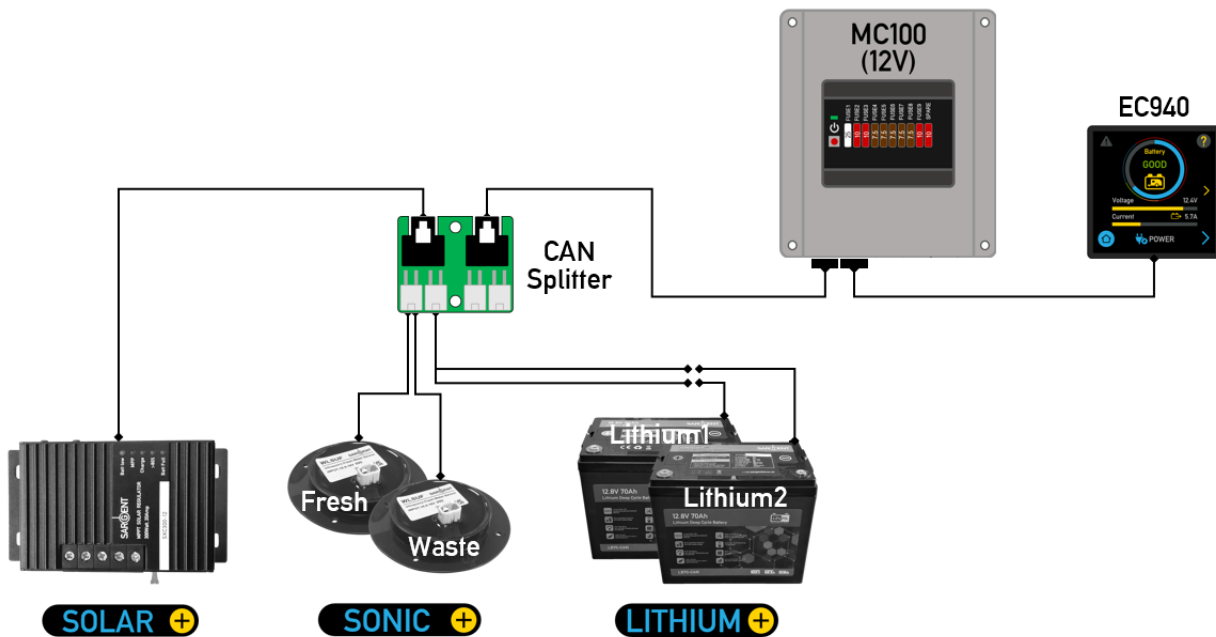

2.3.1 Battery Charger

The wiring harness provided with the kit provides all connections between the Charger, MC100 & MC200 units

- Connect the charger 230V input to the output marked 'Output 4' on the MC200 unit
- Connect the charger 12V output to the input connectors marked 'CHARGER' & 'SIGNALS' on the MC100 unit

Note: the charger 'mains on' signal connects to the MC100 via Pin3 on the 'SIGNALS' connector

Modular Control System (with EC940 Control Panel)

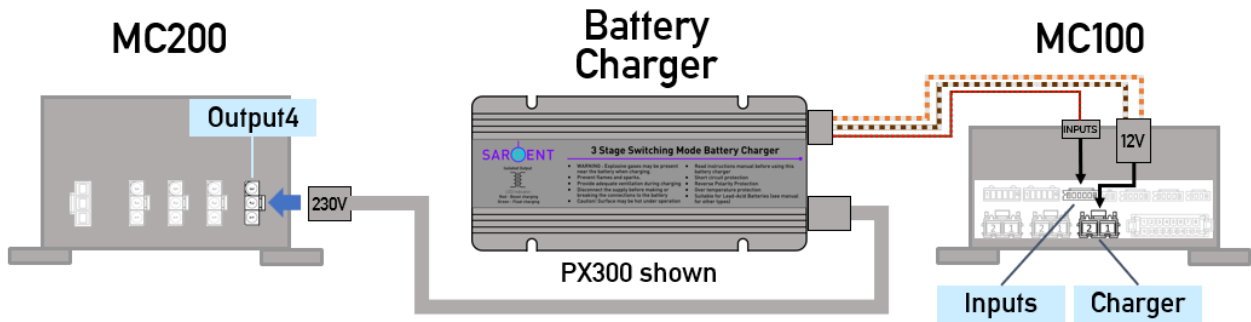

2.3.2 Water Level Sensors

Sensors are provided for monitoring water level in fresh and waste water tanks. For the fresh tank stud sensors are provided to monitor fluid level in 25% steps. For the waste tank a float switch monitors when the tank becomes full. As an option, ultrasonic sensors can be fitted to either tank, allowing the fluid level to be monitored in 1% steps. Due to their non-contact method of sensing, these sensors also require less cleaning and maintenance. Note that ultrasonic sensors are only suitable for tanks at least 100mm deep.

a) Stud & float sensors

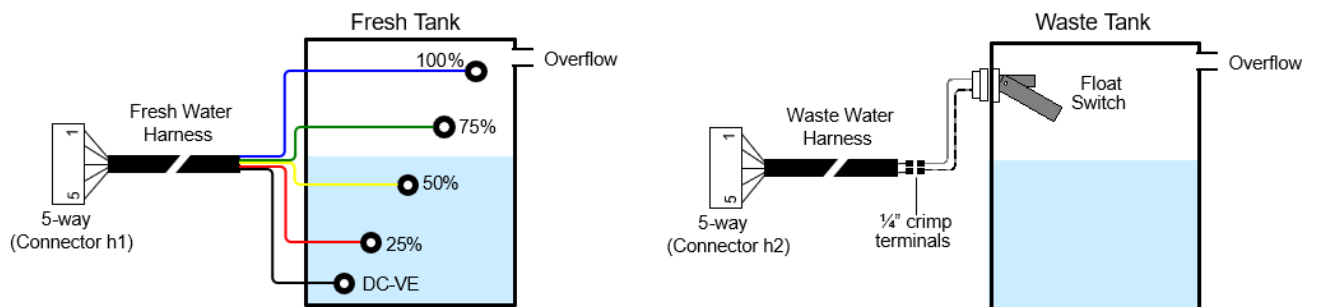

- To fit stud sensors, first drill 5 x 7mm holes in the tank and fit the rubber grommets as shown below. Ensure the DC-VE grommet is fitted below the 25% grommet.
- Attach 5-way wiring harness to each grommet using provided stainless steel bolts and tighten until grommet expands to provide a watertight seal.
- Plug the 5-way connector into the FRESH connector on the MC100 unit (connector h1)
- To fit float sensor, first drill a 20mm diameter hole at the 'tank full' position
Note: The float switch should be positioned below the tank overflow pipe if fitted
- First fit rubber seal then push sensor fully into the mounting hole until it seals tightly
Note: Ensure correct orientation for the sensor, it should be hanging down in the empty position.
- Attach 5-way wiring harness to float switch using 2 x 1/4" crimp terminals
- Plug the 5-way connector into the WASTE connector on the MC100 unit (connector h2)

b) **SONIC** Ultrasonic sensors (optional)

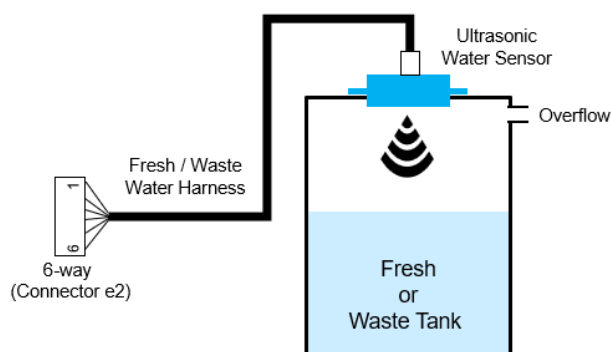

- The sensor should be installed in the top of the tank, as near the centre as possible, to help minimise reading variations should the vehicle be parked on a slope.
- Drill a 57mm hole then fix the sensor in position with 4 x stainless steel self-tapping screws. Use the sealing washer provided to ensure a water tight seal.

Modular Control System (with EC940 Control Panel)

- Connect the CANBus wiring harness to each sensor, ensuring the 4-way waterproof connector is fully locked into place.
- Plug the 6-way end of the wiring harness into a spare CANBus connector on the MC100 unit (connector e2) or if there is no free CANBus connector, use the optional CANBus splitter.
- Before switching on the MC100, ensure there is no water in the tank, so the sensor can self-calibrate once power is first applied. Manual calibration can also be activated from the Advanced Setting menu (see CALIBRATE menu in section 6.1)
- To enable display of water level from the Sonic+ sensor(s), ensure they are first enabled from the Advanced Settings menu (see ACCESSORY > Water CANBUS in section 6.1)

Further information on installation and setup can be found in the WLSU Series Installation & User Instructions, which can be downloaded from the Sargent web site.

2.3.3 External Temperature Sensor

The external temperature sensor should be fitted so at least half of the sensor body is on the outside of the vehicle. Ensure the location is within three metres of the MC100 unit.

- Drill a hole in the floor or the vehicle, then push sensor into position
- Fix sensor with waterproof sealant to ensure there is no water ingress (see diagram)
- Route cable back to MC100 unit and plug into TMP input (Connector g)

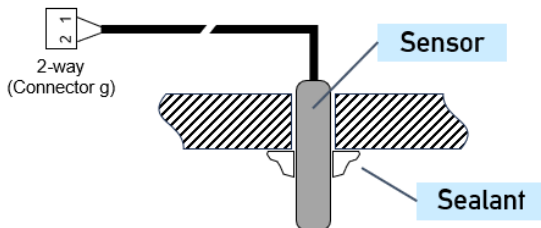

2.3.4 SOLAR Solar Regulator (optional)

The regulator should be installed horizontally or vertically as near the battery as possible but not inside the battery compartment

- Connect the solar panel harness to the 2-way solar input connector
- Connect the Leisure battery and Vehicle battery harness to the 3-way input connector
- Plug 4-way CANBus harness into solar regulator then connect 6-way end into a spare CANBus connector on the MC100 unit (connector e2) or if there is no free CANBus connector, use the optional CANBus splitter.
- To enable display of power from the Solar+ regulator, ensure it is first enabled from the Advanced Settings menu (see ACCESSORY > Solar CANBUS in section 6.1)

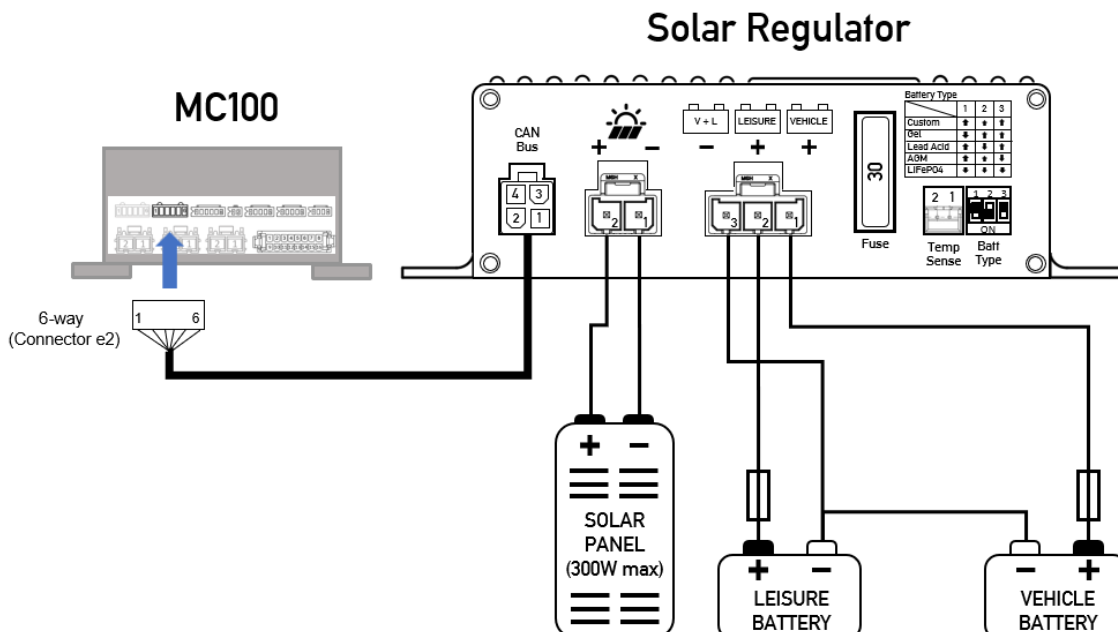

Modular Control System (with EC940 Control Panel)

Further information on installation and setup can be found in the SXC300 Solar Regulator Installation & User Instructions, which can be downloaded from the Sargent web site.

2.3.5 **LITHIUM+** Lithium Battery (optional)

The modular system allows connection of single or dual Lithium+ batteries. Note: When connecting two lithium batteries they must be connected in parallel.

- The batteries should be installed vertically or horizontally and held firmly in place by suitable straps or mounting brackets.
- Ensure the battery cable is suitably rated and fused for the installation, below are suggested ratings

Fuse	Battery to Distribution Unit distance	
	Up to 3m	Up to 6m
20A	3mm ² / 14AWG	4mm ² / 12AWG
30A	4mm ² / 12AWG	6mm ² / 10AWG
40A	6mm ² / 10AWG	10mm ² / 8AWG

- Connect positive(+) cable to the red battery(+) post using a ring terminal suitable for 8mm bolts
- Connect negative(-) cable to the black battery(-) post using a ring terminal suitable for 8mm bolts
- Connect a magnetic CANBus wiring harness to each battery
- A 4-way CANBus extension cable can now be used to connect between the battery and MC100 via a CANBus Splitter
- To enable display of information from the Lithium+ batteries, ensure they are first enabled from the Advanced Settings menu (see POWER > Leisure Battery Type in section 6.1)

Further information on installation and setup can be found in the LB70C_LB100C Lithium Battery Installation & User Instructions, which can be downloaded from the Sargent web site.

Modular Control System (with EC940 Control Panel)

3 Using the System

3.1 Modular Control Unit (MC100) - Component Layout

The MC100 provides protection, monitoring and control for the 12-volt electrical system in the vehicle. The system on/off switch can be used to isolate all 12-volt circuits (except permanent circuits).

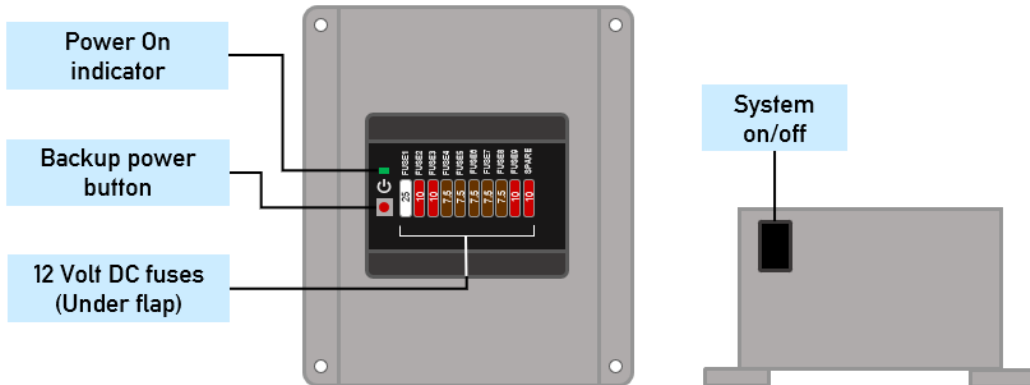

3.2 Modular Consumer Unit (MC200) - Component Layout

The MC200 provides protection and switching control for the 230-volt electrical systems in the vehicle. The RCD switch can be used to isolate power all 230-volt circuits.

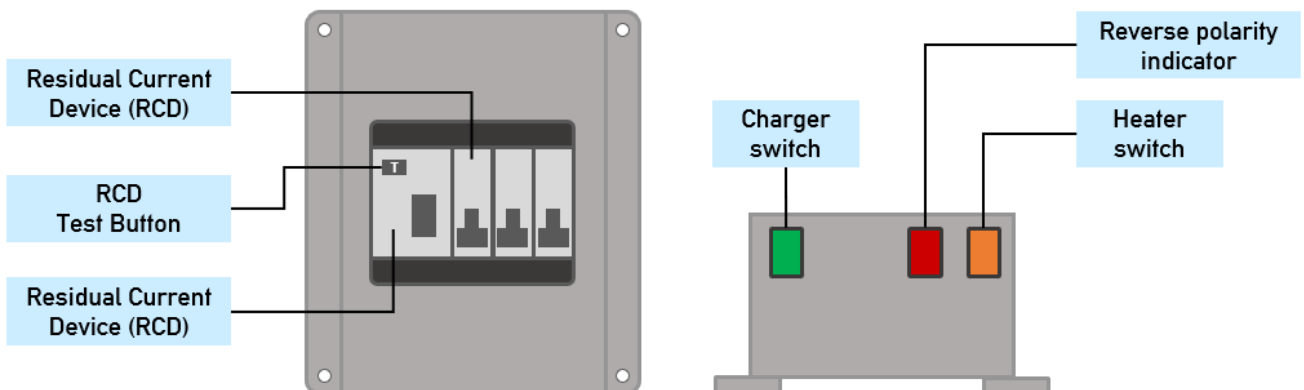

3.3 Activating the System

The system has a shutdown feature that can be used when the vehicle is in storage. This allows the leisure electronics to be turned off when not required to avoid flattening of the leisure and / or vehicle battery. When in the off state only circuits supplied by the permanent 12-volt output are still active, all other supplies are turned off.

Before using the system, please ensure the system shutdown button is in the on position (button in) the system is now active and the Power On indicator will illuminate. The circuits can now be switched on using the control panel (see section 3.7)

3.4 Connecting to the Mains 230V supply and Safety checks

For your safety it is IMPORTANT that you follow these connections instructions each time your Leisure Vehicle is connected to a mains supply. This section assumes that the system is complete and that a Leisure battery has been installed (see section 4.4).

a) Ensure suitability of the Mains Supply

Your Leisure Vehicle should only be connected to an approved supply that meets the requirements of BS7671 or relevant harmonised standards. In most cases the site warden will hold information regarding suitability of supply. If using a generator, you also need to comply with the requirements / instructions supplied with the generator. Please note that some electronic generators may not be compatible with your leisure system. Further generator operational information is contained in section 4.2.

b) Switch the Battery Charger / Power Converter OFF

Modular Control System (with EC940 Control Panel)

Locate the green 'Charger' power switch on the MC200 and ensure the switch is in the off position (button out) before connection to the mains supply.

c) Connect the Hook-up Lead

Firstly, connect the supplied hook-up lead (orange cable with blue connectors) to the Leisure Vehicle and then connect to the mains supply.

d) Check Residual Current Device operation

Locate the RCD within the MC200 and ensure the RCD is switched on (lever in up position). Press the 'Test' button and confirm that the RCD turns off (lever in down position). Switch the RCD back to the on position (lever in up position). If the test button failed to operate the RCD see section 4.1.

e) Check Miniature Circuit Breakers

Locate the MCB's within the MC200 (adjacent to the RCD) and ensure they are all in the on (up) position. If any MCB's fail to 'latch' in the on position see section 4.1.

f) Turn the MC100 ON

Locate the black 'Shutdown' button and ensure it is in the on position (press button in). Locate the green 'Charger' switch on the MC200 and turn to the on position (press button in). The charger switch will illuminate when turned on.

g) Check correct Polarity

Locate the 'Reverse polarity' indicator on the MC200 and ensure that the indicator is NOT illuminated. If the indicator is illuminated see section 4.2.

h) Check operation of equipment

It is now safe to operate the 12V and 230V equipment.

3.5 Operation while driving

The power control system is designed to shutdown parts of the system while the engine is running. This is to meet Electro Magnetic Compatibility (EMC) regulations and to ensure the safe operation of the caravan or motorhome. With the engine running the screen will show a warning 'ENGINE RUNNING'.

Please ensure the system shutdown switch on the MC100 is in the on (button in) position before driving (see 3.3). This will ensure the electronic system is active and will therefore be able to control the charging process and monitor other system circuits.

3.6 Control Panel - Layout

Your control panel will have an appearance as below, but depending on your type of vehicle (caravan or motorhome) the control panel features will vary. Not all features are present in all vehicles.

EC940 Control Panel

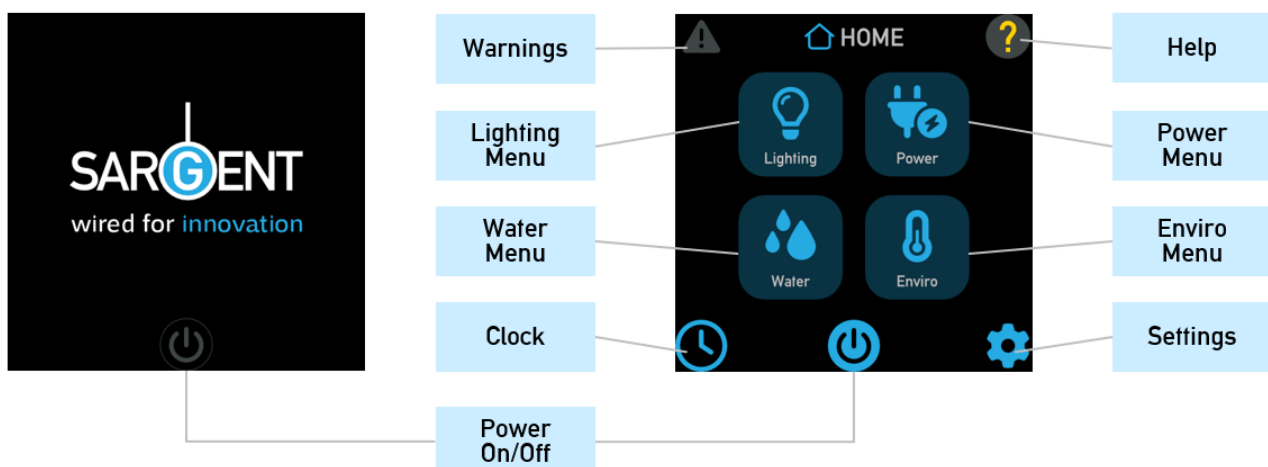

Modular Control System (with EC940 Control Panel)

3.7 Control Panel – Key Features



Power On/Off Button - After activating the MC100 by pressing the System Shutdown Button the display will beep twice and show the start-up logo. To activate power to all circuits, press the power on/off button, the panel will beep once. To turn the power off and enter standby mode, press the power button again. Note: If the display has been inactive for some time, the backlight will be switched off to save power. Simply tap the screen to restore normal brightness.



Lighting Menu - Press the lighting button to show the lighting control screen. Here you can turn on / off or adjust the dimmable lighting levels.



Power Menu - Press the power button to show the power information and control screen. Here you can view leisure/vehicle battery condition, and check battery charger and solar charger currents.



Water Menu – For vehicles fitted with inboard water tanks, press the water button to show the water tank information and control screen. Here you can view tank levels and control related features.



Pump Button – For vehicles not fitted with inboard water tanks, press the pump button to turn the water pump on. Press the button again to turn the pump off. The button border will illuminate when the pump is on.



Environmental Menu - Press the enviro button to show the internal and external temperature in degrees Celsius. Also shown is the internal relative humidity.



Warnings Button - The system incorporates a number of warnings, for example if the battery becomes low. When a warning is active a warning box will appear along with an audible beeping sound. Until the warning has been fully cleared, the warning indicator will remain Red. Press the indicator to view any active warnings.



Help Button - Press the help button to display the context sensitive help screens. These will provide more detail about how to use the currently selected screen.



Clock Button - Press the clock button to display the current time in 24hr format. This screen also provides status tiles for the leisure battery, fresh water tank, 230V mains and solar panel charging, where fitted.



Settings Button - Press the settings button to show the general settings screen. Here you can set the date & time, screen brightness and screen on-time, key beeps etc. There are also buttons on this screen to pair or delete Bluetooth devices. Press the home button to return to the main screen.



Advance button - Pressing this button will advance to the next main section, for example to move between Lighting, Power, Water and Enviro screens

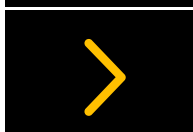

Next Button - Pressing this button moves to the next screen within a section, for example to move between Leisure and Vehicle battery screens



Home Button – Pressing this button will go back to the Main Menu screen

Modular Control System (with EC940 Control Panel)

3.8 Backup Power Button

Should the control panel not power up as expected, the Backup power button can be used to switch on the system and control circuits. Pressing the button for 2 seconds, will enable power and the indicator will illuminate. Then each press of the button will enable switched circuits as shown below. The final button press will switch off the system.

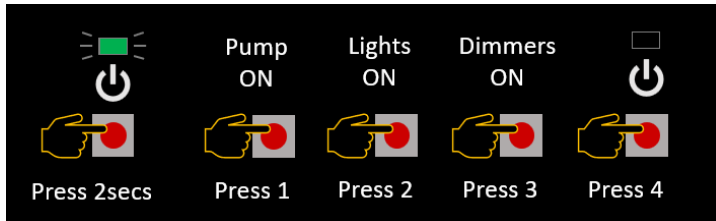

3.9 Clock / Status Screen

Clock screen - This screen not only displays the current time and date but also provides status tiles for the main services in the vehicle such as leisure battery and fresh water tank (if fitted)

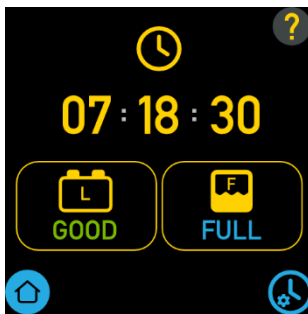

	Leisure Battery – The charge status is shown GOOD – No charge required FAIR – Charge recommended POOR – Charge immediately CHARGING – Charger is switched on DISCONNECTED – No battery detected
	Fresh Water (if fitted) - The water tank level is shown FULL – 100% GOOD – 50% to 99% LOW – 25% to 49% EMPTY – less than 25%
	Clock Setup – Press this button to access the clock setup screen

Clock setup – Use this screen to set the current time and date

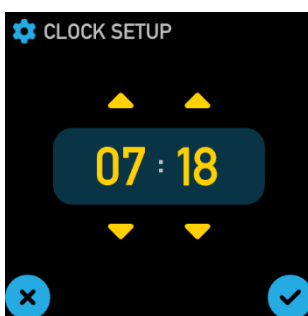

	Set Time – Use the up / down arrows to set the required time
	Confirm settings – Use the tick to confirm the settings or cross to cancel the settings

Note, the clock has a power backup, which can retain the clock settings for a number of weeks. If the vehicle has been stored for longer than this with no 12-volt power, the clock may need to be reset.

3.10 Environmental Readings

The system uses two sensors to measure internal temperature/humidity and external temperature. The combined internal temperature and humidity sensor is furniture mounted within the (caravan / motorhome) and plugs into the rear of the control panel, and the external sensor is mounted below the (caravan / motorhome) floor and plugs into the MC100 unit. The figures displayed are for information only, and it is hoped the information will be useful.

Modular Control System (with EC940 Control Panel)

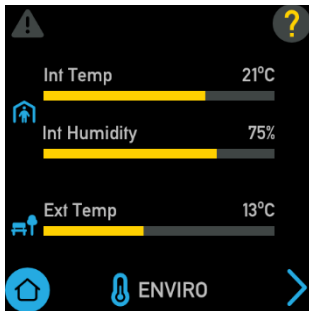

	Internal – The internal temperature and humidity is shown along with a bar graph
	External – The external temperature is shown along with a bar graph

3.11 Water System Operation

The EC940 control panel pump button operates the internal water pump drawing water from an on-board tank if fitted, or an external container when no tank is fitted.

The system incorporates an automatic tank fill feature. When turned on this will automatically fill the on-board water tank from the external container and will switch off automatically when full. To enable tank fill, press *Fill Button* on Fresh Water tank screen. To ensure the external pump is not damaged if the external tank runs dry, the pump runs for a maximum of 7 minutes.

The water tanks (fresh & waste) incorporate a level warning feature to warn the user when the fresh water level drops below 25% or when the waste water level reaches 100%. These warnings can be enabled / disabled from the *User Settings* screen.

If the water pump power is turned on and the fresh water level drops to below 25% a warning beep will be heard and a message will be displayed on the control panel. To cancel the warning, press the bell icon.

If the water pump power is turned on and the waste water level rises to full (100%) a warning beep will be heard and a message will be displayed on the control panel. To cancel the warning, press the bell icon.

These warnings will not be repeated unless the water pump power switch is turned off and on again. This is to ensure the warning does not become a nuisance.

Fresh Water Tank screen (Caravan & Motorhomes). Here you can view the on-board fresh water tank level and control water tank related features.

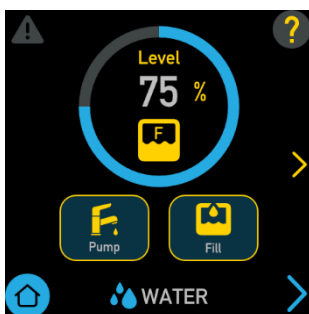

	Fresh Water Level – the water level will be shown on the dial in steps of 25% 0% – Re-fill immediately 25% – Re-fill recommended 50% to 100% – Level OK If an optional Sargent SONIC ultrasonic sensor has been fitted, the level will increase in 1% steps
	Pump Button - Press the pump button to turn the water pump on. Press the button again to turn the pump off. The button will illuminate when the pump is on.
	Fill Button (if fitted) - Press the tank fill button to turn on / off the filling of the on-board water tank from the external water container. The pump will turn off automatically when the on-board tank is full or after 7 minutes have elapsed.

Waste Water Tank screen (Motorhomes only). Here you can view the on-board waste water tank level.

Modular Control System (with EC940 Control Panel)

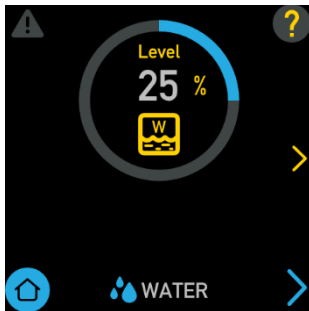

	<p>Waste Water Level – the water level will be shown on the dial in steps of 25%</p> <p>100% – Empty tank immediately 75% – Emptying recommended 0% to 50% – Level OK</p> <p>If an optional Sargent SONIC ultrasonic sensor has been fitted, the level will increase in 1% steps</p>
--	---

3.12 Lighting & Dimming Operation

The Main button switches the primary lighting circuits in the vehicle on or off. The Aux button is used to switch additional lighting such as the awning light or entry light on or off.

The Dimmer button allows the dimmable lighting circuits (if fitted) to be switched on or off. A slider bar allows the lights to be dimmed to the required level.

Lighting screen. Here you can turn lighting on / off or adjust the dimmable lighting levels.

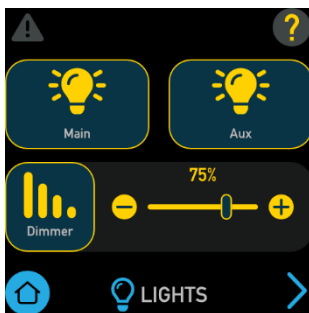

	<p>Main / Aux Button - Press these buttons to control the main interior lighting and any auxiliary lighting e.g., awning light, entry light etc.</p>
	<p>Dimmer Button (if fitted) - Press this button to turn the dimmable lighting on or off.</p>
	<p>Dimming Level (if fitted) - To change the dimming level, either press the (+) or (-) buttons or drag the slider to the required level. The dimming level is shown as a percentage.</p>

3.13 Power Management

The status of the leisure and vehicle batteries can be viewed on the control panel display by selecting the Power menu. Pressing the 'next screen' button will switch between Leisure battery, Vehicle battery and Solar+ charging information (if fitted).

Battery Power screen (12V). Here you can view leisure and vehicle battery levels.

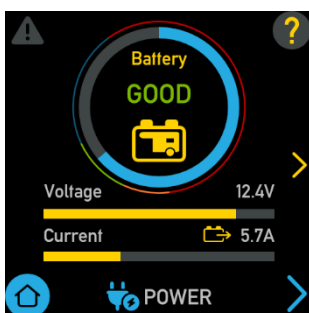

Motorhome example

	<p>Selected Battery - Use the selected battery button to choose which battery you wish to use or charge with the 230V charger. In caravans the vehicle battery will only be available when the caravan is plugged into the car.</p>
	<p>Battery Condition – the battery condition will be shown on the dial and also described as below, GOOD – No charge required FAIR – Charge recommended POOR – Charge immediately CHARGING – Charger is switched on DISCONNECTED – No battery detected</p>

Modular Control System (with EC940 Control Panel)

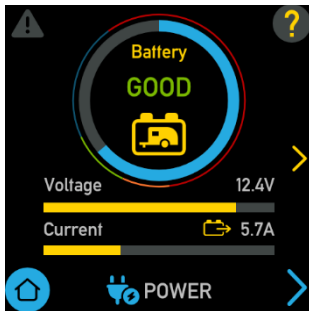

Caravan Example

	<p>Battery Voltage – The voltage value will be shown together with a bar graph</p>
	<p>Battery Current – The battery current will be shown together with a bar graph</p>
	<p>Current Direction – A symbol will show if current is going into or out of the battery or if the battery is inactive.</p>

Lithium+ Power screen (12V). If an optional Sargent **LITHIUM+** battery has been fitted, additional information and a second screen will be available with more information about the battery

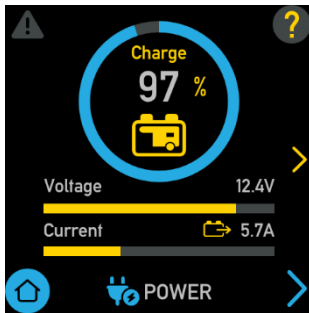

Battery Power screen for Lithium+

	<p>Battery Charge – When using a lithium+ battery, the battery condition gauge will be replaced with a State of Charge gauge 50-100% – No charge required 25-49% – Charge recommended 0-24% – Charge immediately</p>
	<p>Time Remaining – This tile will display the predicted time remaining before the battery is fully discharged or fully charged (as shown by the direction arrow)</p>
	<p>Battery Health – This tile shows the State of Health, which represents how the battery is aging over time. If the battery health is below 50% on a fully charged battery, it's time to consider replacing the battery.</p>
	<p>Battery Capacity – This tile shows the remaining capacity of the battery in Ampere Hours. For a new battery the fully charged capacity will be the rating on the battery label e.g., 70Ah, this will gradually reduce as the battery ages.</p>
	<p>Battery Indicator – This indicator shows if a single or dual lithium battery system is fitted</p>
	<p>Error Indicator – This indicator only lights if there is a problem communicating with the battery. If this happens check the battery communication cable is securely fitted at both ends.</p>

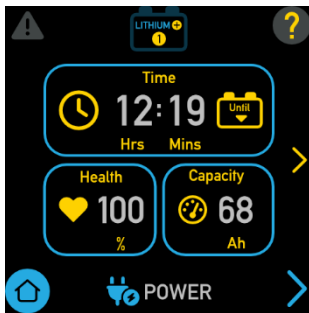

Lithium+ additional screen

Solar+ Power screen (12V). If the optional Sargent **SOLAR+** solar regulator and a solar panel has been fitted, an additional screen will be available with more information about the solar panel charging status

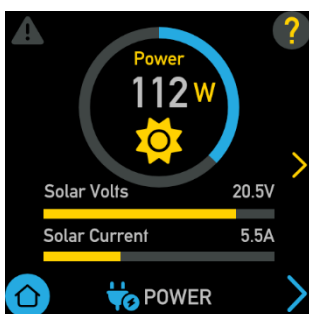

Solar+ additional screen

	<p>Solar Power – The power currently being generated by the solar panel is shown. The dial indicates the power in Watts up to 300, which is the maximum rating if the solar regulator.</p>
	<p>Voltage & Current – The output voltage and current of the solar panel is shown together with a bar graph.</p>

Modular Control System (with EC940 Control Panel)

3.14 Smart Charging

When configured for motorhomes only, the MC100 unit incorporates a smart charge feature, which monitors both leisure and vehicle batteries and automatically adjusts and directs the charger power to maintain the leisure and vehicle batteries at an optimal level.

Note: If the vehicle battery is isolated using the Fiat ignition key isolator or similar, some smart charging functionality will be lost, and the available charge will be directed to the leisure battery.

3.15 System Warnings

The system incorporates a number of warnings that are active at specific times. These are summarised in the table below and also covered by relevant sections of this manual.

Warning screens - When a warning is active a warning screen will appear on the control panel screen containing a description of the warning along with an audible beeping sound.

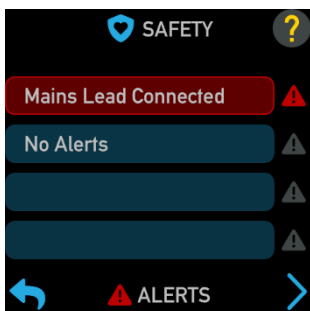

Example safety warnings

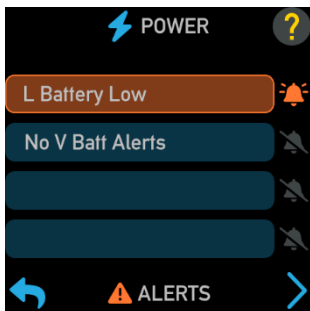



Example Power warnings

	<p>Active Warning – If a warning becomes active, it will be highlighted (Orange for power/water alerts and Red for safety alerts)</p>
	<p>Muting a warning – To mute the warning sound, press the bell icon next to the alert. The icon will then become Grey and the sounder will stop. Note that safety warnings can only be muted by correcting the cause e.g., removing mains lead whilst engine is running</p>
	<p>Clearing a warning – The warning will remain highlighted until it is fully cleared, for example by re-filling the water tank or re-charging the battery</p>

Warning	When	Type
Fresh water level low 	With pump turned on and fresh water level low (less than 25% full) Only available when an on-board tank is fitted	Message on screen and 60 second audible beep
Waste water level full 	With pump turned on and waste water level full. Only available when an on-board tank is fitted	Message on screen and 60 second audible beep
Leisure battery low 	With control panel power on and leisure battery selected (as active battery) and the charge level falls below:- Lead Acid: 11V AGM: 11V Lithium: 12V Lithium+: 15%	Message on screen and 60 second audible beep.

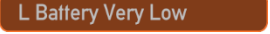
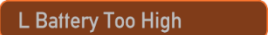
Modular Control System (with EC940 Control Panel)

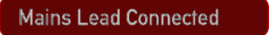

<p>Leisure battery very low</p> 	<p>With control panel power on and leisure battery selected (as active battery) and the charge level is below:- Lead Acid: 10V AGM: 10V Lithium: 11V Lithium+: 5%</p>	<p>Message on screen and 60 second audible beep. If no action taken after 30 seconds, then the system will switch the power off to prevent severe discharge of the battery</p>
	<p>Note: This is an emergency cut off level to protect the battery from severe damage. You should not rely on this cut off level during normal operation, but manage your power consumption to a discharge level of 11.5V or above. This cut off only applies to power drawn from the battery by the leisure equipment that is controlled by the control panel power switch; it will not protect the battery from discharge by permanently connected equipment.</p>	
<p>Leisure battery high</p> 	<p>With control panel power on or off and leisure battery is selected (as active battery) and the voltage level rises above 15.4V</p>	<p>Message on screen and repeated beeps from the control panel. The power is automatically turned off. The beeping will not stop until the fault is cleared.</p>
<p>Vehicle battery warnings</p>	<p>If the vehicle battery is selected instead of the leisure battery, then similar warnings to those described above are applied to the vehicle battery. The vehicle battery low warning level is 10.9V</p>	
<p>Engine running</p> 	<p>When the engine is started the system power will be turned off</p>	<p>Message on screen stating 'engine running'.</p>
<p>Mains lead (hook-up cable) still connected / plugged in</p> 	<p>When the engine is started and the mains cable is still plugged in and the charger is switched on</p>	<p>Message on screen and repeated beeps from the control panel. The beeping will not stop until the hook-up lead is removed.</p>

3.16 User Settings & Bluetooth Pairing

The EC940 control panel has a number of user settings, which can be accessed by pressing the *User Settings* button. This screen also displays the software version number of the MC100, Control Panel and the communicator / tracking unit details if a Sargent EC660 Communication Unit is fitted.

Note:- The Bluetooth section is for future use, and is not currently available with the MC100 unit.

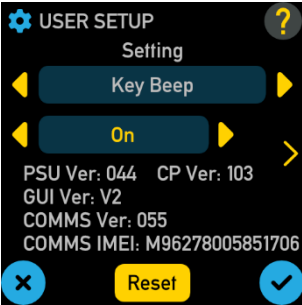
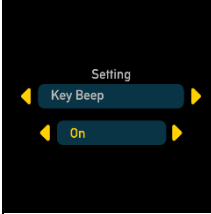
User Settings screen - Here you can set the key beeps, screen brightness, screen on time etc.

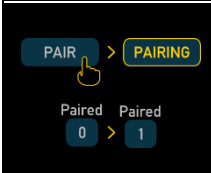
		<p>Settings – Use the arrows to select the setting to adjust, then adjust the setting below as required. Once all required settings have been made, press <i>Tick Button</i> to confirm (see table below for more detail).</p>
		<p>Reset – Press the <i>Reset Button</i> then after a double beep sound, press the <i>Tick Button</i> to reset settings to factory defaults</p>
		<p>** For future use **</p>

Modular Control System (with EC940 Control Panel)

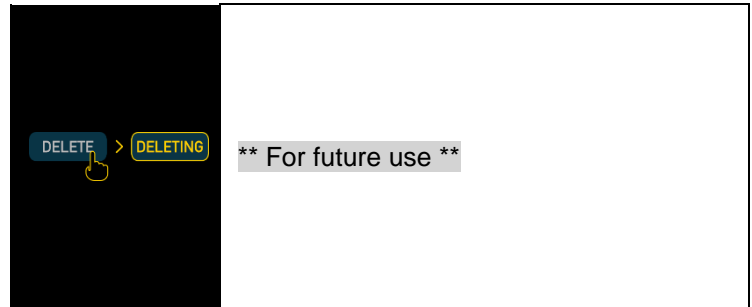
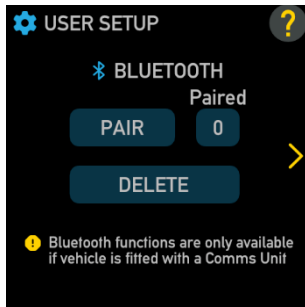

Section	Possible Settings	Description
Key Beep	On / Off	Turn the key beep sound on or off
LCD Brightness	10% to 100%	Adjust screen brightness
Backlight Time	30 seconds to 90 mins	Adjust time before screen backlight goes off
Water Alarms	On / Off	Turn the water alarms beep sound on or off
Lighting Mode	None / Lights / Lights & Dimmer	Sets light behaviour when control panel is switched on, None – Lights stay off Lights – Normal lights come on. Dimmable lights are off. Lights & Dimmer – Normal lights come on. Dimmable lights come on at the last used dim level setting

Modular Control System (with EC940 Control Panel)

4 System Technical Information

The following section provides further technical information relating to the electrical system. You can also access the supporting technical manual from www.sargentltd.co.uk

4.1 Residual Current Device & Miniature Circuit Breakers

The Residual Current Device (RCD) is basically provided to protect the user from lethal electric shock. The RCD will turn off (trip) if the current flowing in the live conductor does not fully return down the neutral conductor, i.e., some current is passing through a person down to earth or through a faulty appliance.

To ensure the RCD is working correctly, the test button should be operated each time the vehicle is connected to the mains supply (see section 3.4)

The Miniature Circuit Breakers (MCB's) operate in a similar way to traditional fuses and are provided to protect the wiring installation from overload or short circuit. If an overload occurs the MCB will switch off the supply. If this occurs you should investigate the cause of the fault before switching the MCB back on.

The following table shows the rating and circuit allocation for the three MCB's

MCB	Rating	Output Wire Colour	Description
1	16 Amps	Yellow	Heating System
2	10 Amps	White	230V Sockets
3	10 Amps	Black	Fridge / Charger

4.2 Generator Usage

Caution should be used before connecting a generator to your caravan or motorhome.

WARNING

Never start or stop the generator while electrical loads are connected and switched on. Start the engine, let it stabilise and then connect the electrical load. When stopping the generator, disconnect the electrical load and let engine stabilise before switching off.

Whilst some generators use electronic inverter technology, others use a more basic principle to generate the 230V supply. Preference should be to choose a generator which produces a consistent sinusoidal wave form with accurate voltage control.

The Reverse Polarity warning light on the MC200 mains unit may illuminate when using a generator. This is a normal side effect when using some types of generators. Instead of connecting the neutral conductor to earth, some generators centre-tap the earth connection making both neutral and live conductors 110V above earth. This 110V difference causes the neon polarity indicator to illuminate.

In most cases it is safe to use a generator, but please consult the generator handbook for further information.

4.3 Battery Charger

The system incorporates an input to allow connection of an external battery charger such as the Sargent PX300

Modular Control System (with EC940 Control Panel)

4.3.1 PX300 – 300Watt, 3-Stage Battery Charger

During stage 1 the battery voltage is increased gradually while the current is limited to start the charging process and protect the battery. At stage 2 the voltage rises to 14.4V to deliver the bulk charge to the battery. When the battery is charged, the voltage is decreased at stage 3 to 13.6V to deliver a float charge to maintain the battery in the fully charged state. The charger can be left switched on continuously as required.

The battery charger / power converter also provides power to the leisure equipment when the mains supply is connected. This module supplies DC to the leisure equipment up to a maximum of 25 Amps (300 Watts), therefore the available power is distributed between the leisure load and the battery.

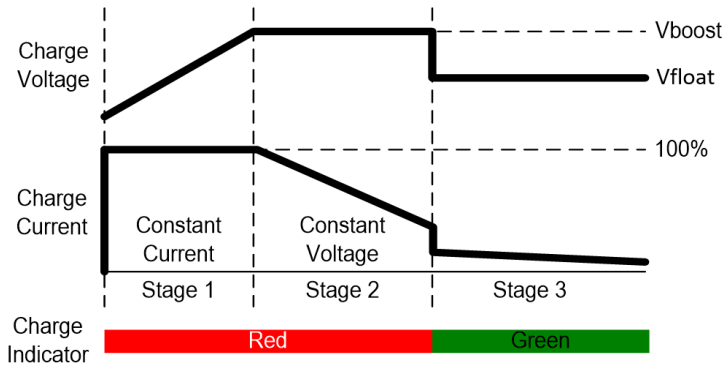

WARNING

Under heavy loads the Battery Charger case may become hot. ALWAYS ensure the ventilation slots have a clear flow of air. Do not place combustible materials against / adjacent to the charger.

4.4 Leisure Battery

4.4.1 Type / Selection

For optimum performance and safety, it is essential that only a proprietary brand LEISURE battery is used and it is suggested to select a battery from the NCC Verified Battery Scheme with a typical capacity of 75 to 180 Ah (Ampere / hours). Depending on the prospective use of the vehicle the correct type should be selected (A, B or C). A normal car battery is NOT suitable. This battery should always be connected when the system is in use.

The MC100 is configured to work with standard lead acid leisure batteries, and in most cases is also compatible with the latest range of Absorbed Glass Matt (AGM) batteries. The system is also suitable for Lithium batteries with built-in Battery Management Systems (BMS) such as the Sargent Lithium+ Series (see section 2.3.5)

Before fitting non-standard batteries please check that the charging profile described in section 4.3.1 is suitable for the type of battery by referring to the battery documentation or battery manufacturer.

Some vehicle installations can cater for two leisure batteries connected in parallel. In these cases, it is recommended that two identical batteries are used.

The leisure (and vehicle) battery feed should be protected with an inline fuse between the battery and the electrical harness, and this fuse should be located immediately outside the battery compartment or within 500mm of the battery. The recommended fuse rating is 20A per battery.

4.4.2 Installation & Removal

Always disconnect the 230V mains supply and turn the green charger switch on the MC200 to the off position (button out) before removing or installing the battery.

When connecting the battery, ensure that the correct polarity is observed (black is negative [-] and red is positive [+]) and that the terminals are securely fastened. Crocodile clips must not be used.

Note: If a tracking solution is fitted with an active Thatcham subscription, it is advised to inform the tracking call centre before removing the battery, to avoid an unnecessary security call.

WARNING

Explosive gases may be present at the battery. Take care to prevent flames and sparks in the vicinity of the battery and do not smoke.

Modular Control System (with EC940 Control Panel)

4.4.3 Operation / Servicing

This information relates to lead acid batteries, other specific requirements may be relevant if lithium batteries are fitted, therefore please refer to the battery documentation.

Under normal circumstances it should not be necessary to remove the battery other than for routine inspection of the terminals and “topping up” of the battery fluid where applicable. Please see instructions supplied with the battery.

Note: Do not over discharge the battery. One of the most common causes of battery failure is when the battery is discharged below the recommended level of approximately 10V. Discharging a battery below this figure can cause permanent damage to one or more of the cells within the battery.

To prevent over discharge, the MC100 system incorporates a battery protect circuit that warns the users and then disconnects the batteries when they fall below set values.

If a warning is active a beep will be emitted by the control panel and information will be shown on the screen. To mute the warning, press the bell icon. These warnings will not be repeated unless the power switch is turned off and on again. This is to ensure the warning does not become a nuisance.

Battery	Voltage cut off	Action after cut off	Notes
Vehicle	10.9V	Battery selection is changed from Vehicle battery to Leisure battery. If the leisure battery is below 9V then a further warning will occur (see below).	This cut off level is designed to protect the vehicle battery from over discharge. The 10.9V level ensures there is sufficient power in the battery to run the vehicle electronics and start the vehicle. This cut off only applies to power drawn from the battery by the leisure equipment; it will not protect the battery if you leave vehicle circuits switched on, such as the road lights.
Leisure	Lead Acid: 10V AGM: 10V Lithium: 11V Lithium+: 5%	Power is turned off	This is an emergency cut off level to protect the battery from severe damage. You should not rely on this cut off level during normal operation, but manage your power consumption to a discharge level of about 11.5V. This cut off only applies to power drawn from the battery by the leisure equipment that is controlled by the control panel power switch; it will not protect the battery from discharge by permanently connected equipment.

4.5 12 Volt DC Fuses

WARNING

When replacing fuses always replace a fuse with the correct value. NEVER replace with a higher value / rating as this could damage the wiring harness. If a replacement fuse 'blows' do not keep replacing the fuse as you could damage the wiring harness. Please investigate the fault and contact your dealer.

The following table shows the fuse allocation for the 9 fuses fitted to the MC100. Please note that fuses are dependent on system versions, so not all fuses may be present.

Fuse	Rating	Fuse Colour	Description
1	25 Amps	White	Charger
2	10 Amps	Red	12V Sockets / USB Sockets
3	10 Amps	Red	Main Lighting
4	7.5 Amps	Brown	Auxiliary / Awning Lighting
5	7.5 Amps	Brown	Filler Pump
6	7.5 Amps	Brown	Pump
7	7.5 Amps	Brown	Dimmable Lighting

Modular Control System (with EC940 Control Panel)

8	7.5 Amps	Brown	Permanent (Unswitched)
9	10 Amps	Red	Compressor Fridge (Permanent Switched)

Note: Fuses (2-9) have a Red LED below them which provides indication that the fuse has blown.

The following table shows details of the recommended fuse(s) located at each battery.

Fuse	Rating	Fuse Colour	Description
Leisure Battery 1	20 Amps	Yellow	Fuse remotely located near battery1
Leisure Battery 2	20 Amps	Yellow	Fuse remotely located near battery2
Vehicle Battery	20 Amps	Yellow	Fuse remotely located in supply from vehicle battery

4.6 Common Fault Table

Fault	Possible Cause	Proposed Fix
No 230-volt output from MC200	Connecting lead between the site and Leisure Vehicle not connected	Check and connect lead as per 3.4c
	RCD switched off	Reset RCD as per 3.4d
	RCD not operating correctly	Check supply polarity; if the RCD continues to fail contact your Dealer as there is probably an equipment or wiring fault.
	MCB switched off	Reset MCB by switching OFF (down position) then back ON (up position), if the MCB continues to fail contact your Dealer as there is probably an equipment or wiring fault.
	No or deficient supply from site	Contact site Warden for assistance.
	Another fault	Contact your Dealer.
Reverse Polarity light is illuminated on MC200	Mains Supply reversed?	The reverse polarity light is designed to illuminate when the Live and Neutral supply has been reversed / crossed over. If the light illuminates there is a problem with the site supply or the cable connecting the supply to your vehicle. The light is designed to work on UK electrical supplies (where the neutral conductor is connected to earth at the substation). If you are using your vehicle outside the UK this light may illuminate when no fault exists. In these cases, consult the site warden for advice.
	Generator being used	'The Reverse Polarity warning light is on when using my Generator'. This is a normal side effect when using some types of generators. Instead of connecting the neutral conductor to earth, some generators centre-tap the earth connection making both neutral and live conductors 110V above earth. This 110V difference causes the neon polarity indicator to illuminate. In most cases it is still safe to use the generator, but please consult the generator handbook for further information.
Control Panel Problems	Control Panel has no display	Check batteries and fuses, turn system isolate switch and charger switch on and ensure mains supply is connected. Check control panel connecting lead at MC100 and behind Control Panel. Contact your Dealer.

Modular Control System (with EC940 Control Panel)

Fault	Possible Cause	Proposed Fix
	12V Power turns off	Battery protect feature has operated to protect the Vehicle battery and or the Leisure battery. See 4.4c Over voltage protection has been activated, the control panel will display a warning. A number of things can cause this but the most common is the solar panel, it is worth checking the regulator is connected correctly and operating within the correct parameters. Engine has been started; all equipment has been disconnected to meet EMC requirements. See 3.5
	Control Panel locked / erratic function	Observe control panel handling instructions. Control panel software may have crashed. Reboot control panel by turning off the MC100 isolate switch. Wait 30 seconds then turn the switch back on. Check with your dealer that your system has the latest software installed, as an update may be available.
No 12-volt output from MC100	No 230V supply	Check all above.
	Charger not switched on	Turn on charger switch (on MC200), switch will illuminate.
	Battery not connected and / or charged	Install charged battery as per 4.4
	Power button on control panel not switched to on	Turn power on at control panel.
	Battery flat / Battery fuse blown	Recharge battery, check fuses, check charging voltage is present at battery.
	Fuse blown	Check all fuses are intact and the correct value fuse is installed as per fuse table.
	Equipment switched off / unplugged	Check equipment is switched on and connected to the 12V supply.
	Another fault	Contact your Dealer.
Pump not working	Fuse blown	Replace fuse with correct value as per fuse table.
	Pump turned off	Turn pump on by pressing the pump button at the control panel.
Lights not working	Fuse/s blown	Replace fuse with correct value as per fuse table.
	Lights turned off	Turn Lights on by pressing the lights button, use dimmer at the control panel.

4.7 Technical Support

If you require technical support on Sargent products then please visit the Support Customer Support site at <https://sargent.zohodesk.eu/portal/en/home> In the Knowledge Base you can view product documentation and search frequently asked questions and in the Ticket section you can raise a ticket to request help from the support team.

4.8 Updates

From time to time there may be updates to the system firmware; these updates will be done at service intervals by your dealership.

Modular Control System (with EC940 Control Panel)

5 Technical Data & Approvals

5.1 Equipment – MC100, MC200, EC940

Outline Specification – MC200		
INPUT 230V	230 Volts / 0 to 16 Amps	+ / - 10%
OUTPUT 230V	RCD protected, 1 x MCB output of 16A, 2 x MCB outputs of 10A Separate switched channels for heating system and charger	
Outline Specification – MC100		
VEHICLE & LEISURE Inputs	2 x 20A battery inputs via 2 x 2-way connectors	
CHARGER Input	1 x Dedicated battery charger input capable of supporting up to 25A charger via a 2-way connector	Check the charger rating plate to ensure the maximum current is <= 25A
OUTPUTS	25A total output via multiple switched channels protected by 8 fused outputs	
INPUTS (Signals)	Engine running, plus multiple vehicle connections	
TMP Input	1 x Temperature sensor	
FRESH & WASTE Inputs	4 x Fresh water level, 4 x Waste water level	Fresh water negative sensed Waste water negative sensed
SWITCH Inputs	2 x Momentary switch inputs	
DATA In / Out	2 x CANBus Data communication & Power for Control Panel and other CAN accessories	
IP rating	IP31	
Operating temperature	Ambient 0 to 35° Celsius Charger case temperature with full load 65° C Max	Automatic shutdown and restart if overheated / overloaded
Dimensions		
MC100 Mains Unit	Overall size (HxWxD) 180 x 166 x 75mm Clearances 75mm above, 50mm left & right	Weight 0.71 Kg
MC200 Control Unit	Overall size (HxWxD) 190 x 166 x 95mm Clearances 75mm above, 50mm left & right	Weight 1.24 Kg
EC940 Control Panel	Overall size (HxWxD) 94 x 94 x 26mm Cut-out size (HxW) 86 x 86mm	Fixing via hidden spring clips Weight 135g
Temp / Humidity Sensor	Overall size (HxWxD) 35 x 20 x 36mm Cut-out size (HxW) 26 x 14mm	

5.2 Approvals

Power Supply Unit: Automotive Electro Magnetic Compatibility (EMC) to ECE Reg10.06, Type approval number E11 10 R 06 12228

Control Panel: Automotive Electro Magnetic Compatibility (EMC) to ECE Reg10.06, Type approval number E11 10 R 06 12231

System: BSEN 1648-1, BSEN1648-2 compliant, BS7671: 2018 compliant

Residual Current Device: RCD 40A 30mA trip to BS EN 61008

Miniature Circuit Breakers: MCB's type C 6000A breaking capacity to BSEN 60898

Modular Control System (with EC940 Control Panel)

Integrated Charger: BS EN 60335-1/2.29, 2006/95EC, IEC61000-3.2/3:1995, 1.

Low Voltage Directive: 2006/95EC TUV-014900-A1, EN55022, Class B, EN55024/ Level 2

5.3 Declaration of Conformity

Equipment: Leisure Power Control System

Model name(s): MC100, MC200, EC940

I hereby declare that the equipment named above has been designed to comply with the relevant sections of the above referenced approvals. The unit complies with all essential requirements of the Directives.

Signed	Name	Position	Manufacturer
	I L Sargent	Technical Director	Sargent Electrical Services Ltd Unit 35, Tokenspire Business Park, Woodmansey, Beverley East Yorkshire, United Kingdom
Date: 26/01/24			

Whilst every effort has been made to ensure the accuracy and completeness of this document, no guarantee is given against errors or omissions. This document may be updated / improved over time therefore please check with your dealer / supplier for update information or visit www.sargentltd.co.uk

5.4 Electrical Connections – MC100

a) VEHICLE BATTERY Connector (12V)

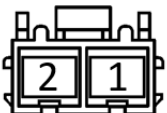
	Pin	Function	Fuse	Wire Colour
	1	Vehicle Battery -	-	WHITE / ORANGE
	2	Vehicle Battery +	-	BROWN / GREEN

b) LEISURE BATTERY Connector (12V)

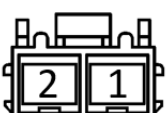
	Pin	Function	Fuse	Wire Colour
	1	Leisure Battery -	-	WHITE / ORANGE
	2	Leisure Battery +	-	BROWN / BLUE

c) CHARGER Connector (12V)

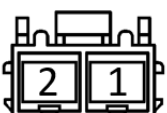
	Pin	Function	Fuse	Wire Colour
	1	Charger -	-	WHITE / ORANGE
	2	Charger +	-	BROWN / WHITE

d) OUTPUTS Connector (12V)

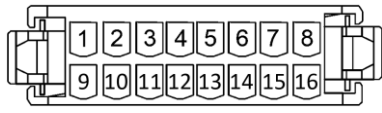
	Pin	Function	Fuse	Wire Colour
	1	Permanent +12V (switched) e.g. Compressor Fridge	9	RED
	2	Permanent +12V (unswitched) e.g. Tracker / Alarms	8	RED
	3	Dimmable Lights +12V *	7	RED
	4	Pump +12V *	6	RED
	5	Filler Pump +12V *	5	RED

Modular Control System (with EC940 Control Panel)

	6	Aux / Awning Light +12V *	4	RED
	7	Main Lights +12V *	3	RED
	8	12V Sockets / USB +12V / Toilet / Ignitions	2	RED
	9-16	0V	-	BLACK

e) CAN Bus Connector (x2)

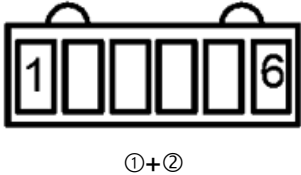
	Pin	Function	Fuse	Wire Colour
	1	12V	-	RED
	2	12V	-	WHITE
	3	Data H	-	GREEN
	4	Data L	-	YELLOW
	5	0V	-	BLUE
	6	0V	-	BLACK

f) INPUTS Connector (Signals)

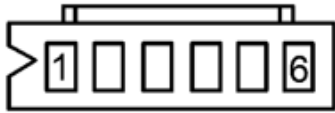
	Pin	Function	Fuse	Wire Colour
	1	-	-	-
	2	D- / Negative	-	WHITE / BROWN
	3	Ignition / D+	-	BLUE
	4	Lock	-	RED
	5	Unlock	-	BLACK / RED
	6	Mains On	-	BROWN / RED

g) TMP Connector (External Temperature)

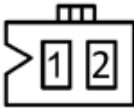
	Pin	Function	Fuse	Wire Colour
	1	Temperature sensor (10K)	-	BLACK
	2	Temperature sensor (10K)	-	BLACK

h) FRESH & WASTE Connector (x2)

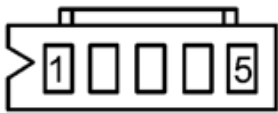
	Pin	Function	Fuse	Wire Colour
	1	0V	-	BLACK
	2	25%	-	RED
	3	50%	-	YELLOW
	4	75%	-	GREEN
	5	100%	-	BLUE

i) SWITCH Connector

	Pin	Function	Fuse	Wire Colour
	1	** For future use **	-	-
	2	** For future use **	-	-
	3	** For future use **	-	-
	4	** For future use **	-	-



Modular Control System (with EC940 Control Panel)

5.5 Electrical Connections – MC200

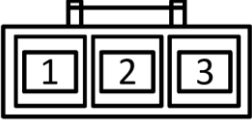
a) 230V Input Connector

	Pin	Function	MCB	Wire Colour
	1	230V Neutral Input	-	BLUE
	2	Earth	-	GREEN / YELLOW
	3	230V Live Input	-	BROWN

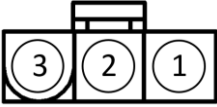
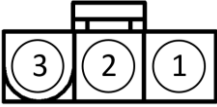
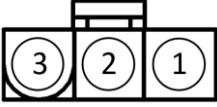
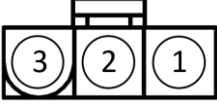
b) 230V Output Connectors (left to right)

 <p>①</p>	Pin	Function	MCB	Wire Colour
	1	Output1 230V Live – Heater	1 (16A)	BROWN
	2	Earth	-	GREEN / YELLOW
	3	Output1 230V Neutral – Heater	1 (16A)	BLUE
 <p>②</p>	Pin	Function	MCB	Wire Colour
	1	Output2 230V Live – Sockets	2 (10A)	BROWN
	2	Earth	-	GREEN / YELLOW
	3	Output2 230V Neutral – Sockets	2 (10A)	BLUE
 <p>③</p>	Pin	Function	MCB	Wire Colour
	1	Output3 230V Live – Fridge	3 (10A)	BROWN
	2	Earth	-	GREEN / YELLOW
	3	Output3 230V Neutral – Fridge	3 (10A)	BLUE
 <p>④</p>	Pin	Function	MCB	Wire Colour
	1	Output4 230V Live - Charger	3 (10A)	BROWN
	2	Earth	-	GREEN/YELLOW
	3	Output4 230V Neutral - Charger	3 (10A)	BLUE
	Pin	Function	MCB	Wire Colour
	-	Earth Bond	-	GREEN/YELLOW

Modular Control System (with EC940 Control Panel)

5.6 12V Wiring Diagram – Motorhome c/w Compressor Fridge

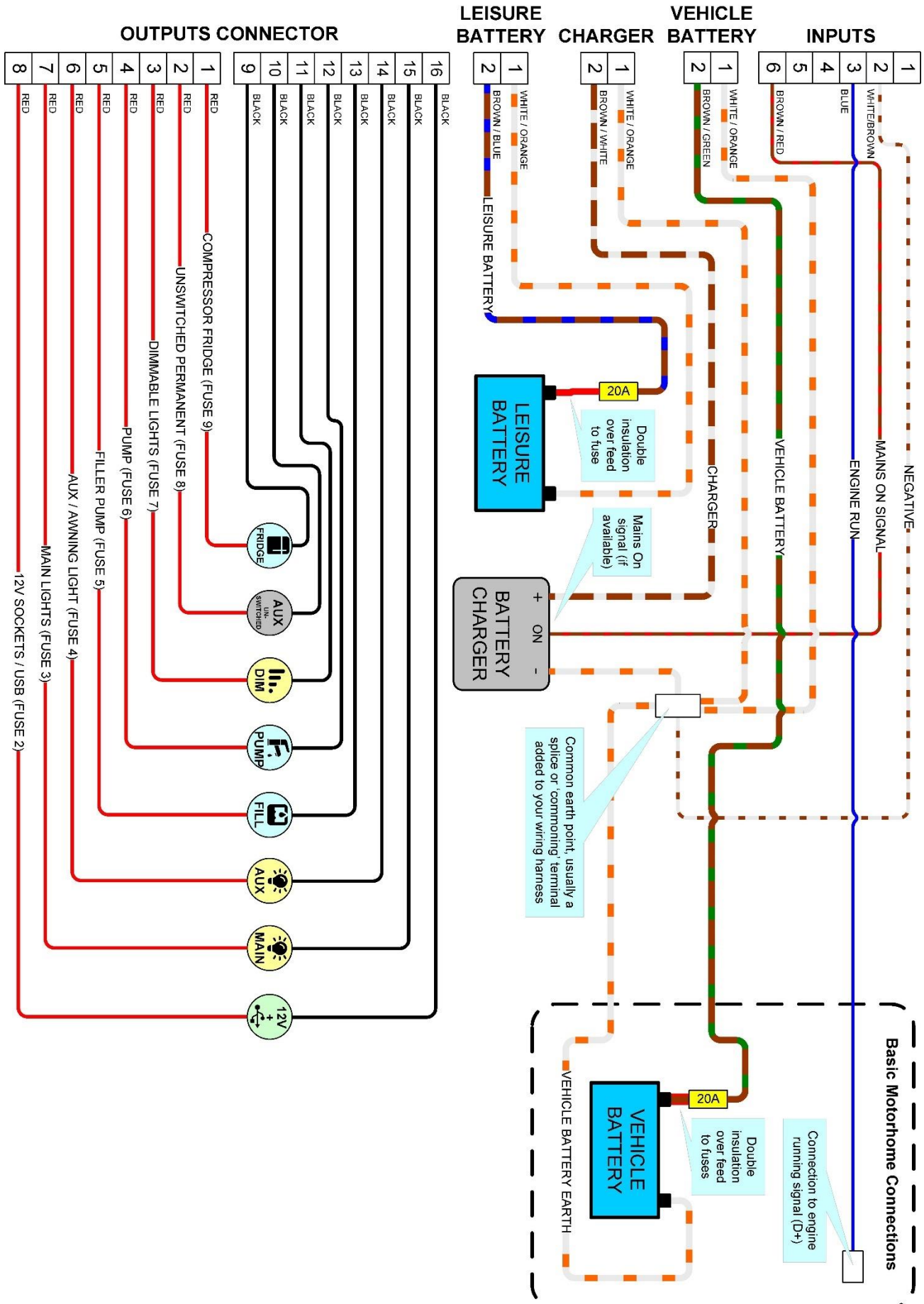

Modular Control System (with EC940 Control Panel)

5.7 12V Wiring Diagram – Caravan c/w Compressor Fridge

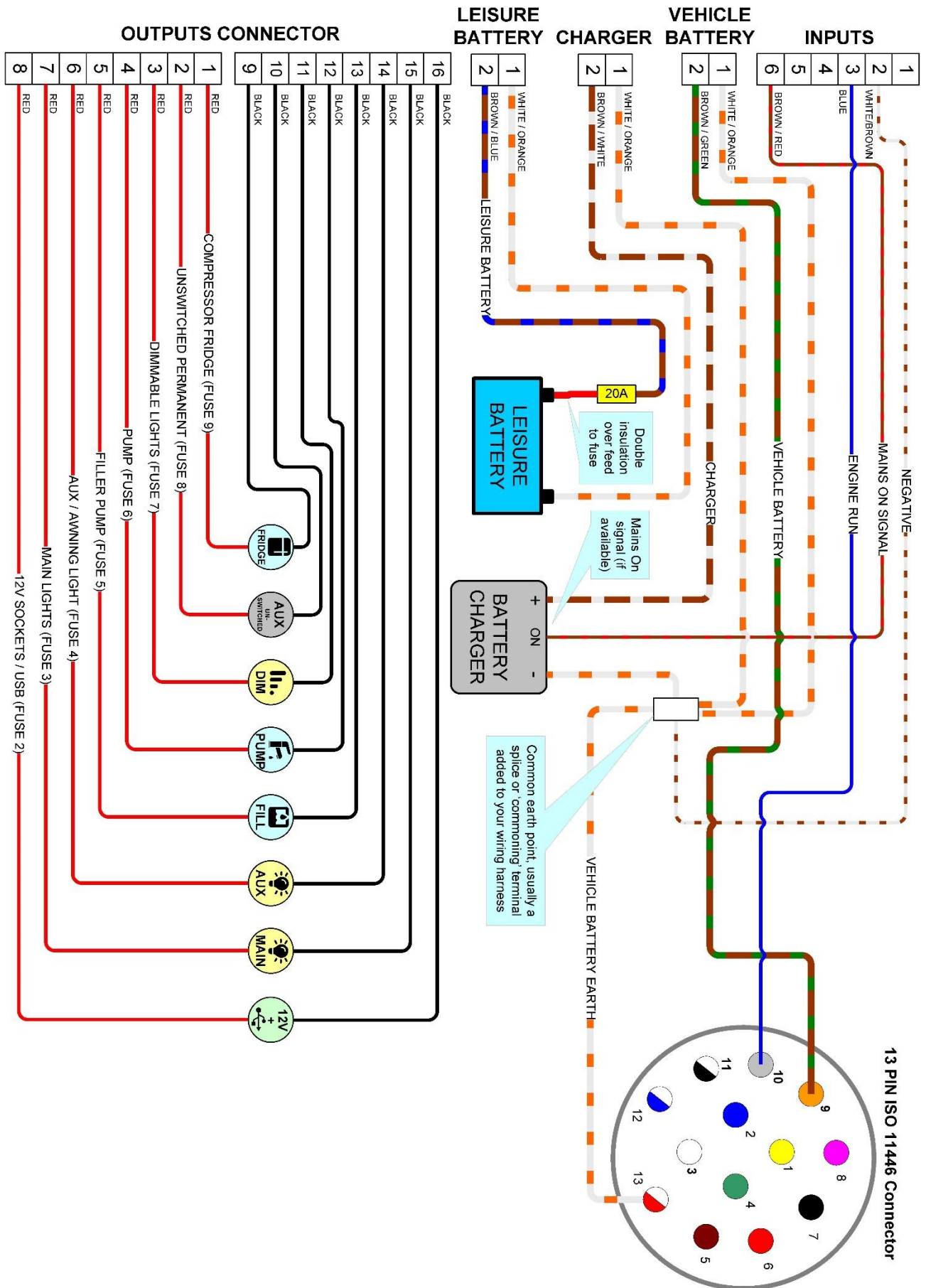

Modular Control System (with EC940 Control Panel)

5.8 12V Wiring Diagram – Caravan c/w Absorption Fridge

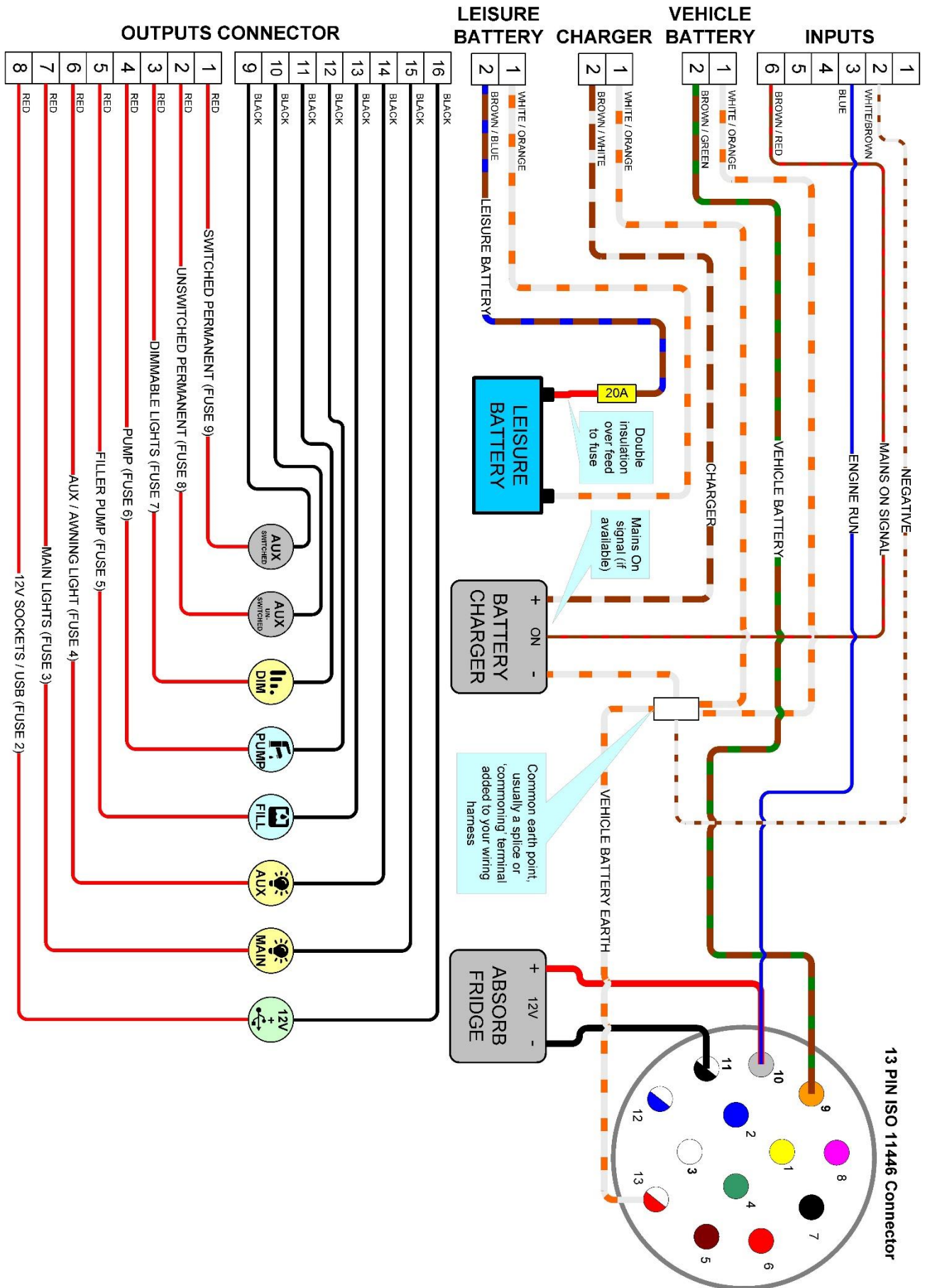

Modular Control System (with EC940 Control Panel)

6 Advanced Settings

In order for installers to configure the system for specific equipment and installations, the control panel incorporates an advanced settings menu. This can be accessed by pressing and holding the settings button (gear wheel) from the home screen.

Once inside the advanced settings, a screen will display as below

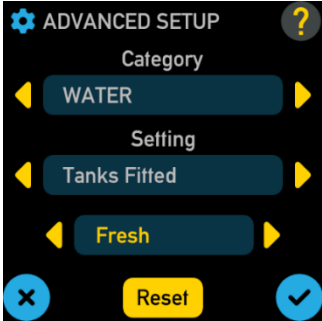

<div style="background-color: black; color: white; padding: 5px; text-align: center;"> <small>Category</small> WATER </div>	<p>Category – Use the arrows to select the category to adjust</p>
<div style="background-color: black; color: white; padding: 5px; text-align: center;"> <small>Setting</small> Tanks Fitted Fresh </div>	<p>Setting – Use the arrows to select the setting to adjust, then adjust the setting below as required. Once all required settings have been made, press <i>Tick Button</i> to confirm (see table below for more detail).</p>
<div style="background-color: black; color: white; padding: 5px; border: 1px solid white; width: 50px; margin: 0 auto;"> Reset </div>	<p>Reset – Press the <i>Reset Button</i> then after a double beep sound, press the <i>Tick Button</i> to reset settings to factory defaults</p>

6.1 Changing a setting

Select a 'Category' from the first menu e.g., WATER

Select the particular item to be changed from the 'Setting' menu e.g., Tanks Fitted

Then finally select the value required from the bottom menu e.g., Fresh

Once all the required settings have been changed, press the 'tick' symbol to confirm, after a short delay a double beep will confirm the changes have been saved before exiting.

Pressing the 'cross' symbol will cancel any changes and exit.

All accessible menu items are shown below

Category	Setting	Value	Comments
VEHICLE	Vehicle Type	CV Swift	** Do not use **
		MH Swift	** Do not use **
		Auto-Trail EC970	** Do not use **
		Bilbo Campers	** Do not use **
		Auto-Trail EC940	** Do not use **
		MH Auto-Sleeper	** Do not use **
		Camper King	** Do not use **
		Campervans	** Do not use **
		CV Swift EC400+	** Do not use **
		MH Swift EC400+	** Do not use **
		Type-12-Unused	** Do not use **
		CV EC9xx	Caravan fitted with MC100
		MH EC9xx	Motorhome fitted with MC100
	Logo	Sargent	Bootup logo screen
		Auto-Trail	** Do not use **
Auto-Sleepers		** Do not use **	

Modular Control System (with EC940 Control Panel)

		Swift	** Do not use **
		Slot 5	** Do not use **
		Wellhouse	** Do not use **
		Slot 7	** Do not use **
	Engine Run Detect	Normal D+	Engine running mode is enabled as soon as the D+ signal from the car or motorhome cab becomes active.
		Delayed D+	** Do not use **
		Delayed IGN	Engine running mode is enabled 10 seconds after an Ignition On signal from the car or motorhome cab becomes active.
		Volt Detect IGN	Engine running mode is enabled once the Ignition On signal from the car or motorhome cab increases above 13.5 volts
		CI-BUS LEVC	** Do not use **
	Internal Temp Sensor Location	PSU	** Not available on MC100 **
		Control Panel	Internal Temp sensor connected to Control Panel
	Enroute	None	** Not available on MC100 **
		Active	
	Step Fitted	Not Fitted	** Not available on MC100 **
		Fitted	
	Step Automation	None	** Not available on MC100 **
		Lock	
		Unlock	
		Both	
	Step Count Time	20.....200 (Default: 30)	** Not available on MC100 **
	Tracker Trigger Mode	Alarm	Tracker is triggered by alarm system or keypad (Default for caravans).
		Engine	Tracker is triggered if vehicle is moved with engine off (Default for motorhomes).
LIGHTS	LED PWM Frequency	Low / Normal / High (Default: Normal)	Sets the dimmer channel frequency. If a customer can perceive the lighting flickering or if radio noise is present, it can be changed.
	Awn Light Automation	None	Turns awning light automation off.
		Lock	Aux light will switch on when vehicle doors are locked.
		Unlock (Default)	Aux light will switch on when vehicle doors are unlocked.
		Both	Aux light will switch on when vehicle doors are locked or unlocked.
	Awning Light Time	30.....240 Secs (Default: 30 Secs)	Adjust the illumination time for the awning & entry light automation feature.
		1 Channel	Sets 1 x dimming channel

Modular Control System (with EC940 Control Panel)

	Dim Channels Fitted	(Default)	
		None	Switch off dimming channels
POWER	Leisure Battery Type	Lead Acid (Default)	Sets the chemistry of leisure battery fitted. Battery voltage warnings will be adjusted to suit the different types of battery.
		AGM	
		Lithium	
		Lithium+	Sets if Sargent CAN-Bus enabled lithium batteries are fitted, which provide additional information on the control panel screen.
		Lithium+ x2	
	Split Charge	Normal (Default)	The integrated split charging relay is enabled, allowing the leisure battery to be charged during driving.
		Off	The integrated split charging relay is disabled. Use this setting if a DC-DC charger has been fitted.
	Smart Charging	Normal	Smart charging turned off
		Smart 2	Smart on, 2-hour cycle time
		Smart 3	Smart on, 8-hour cycle time
		Smart	Default setting, 4-hour cycle time
	Solar Smart Charging	Leisure	** Not available on MC100 **
		Vehicle	
		Smart	
WATER	Tanks Fitted	None	No on-board water tanks fitted
		Fresh	Fresh water on-board tank fitted
		Both	Fresh & Waste water on-board tanks fitted
	Tank Heaters	Not Fitted (Default: Caravans)	** Not available on MC100 **
		Fitted (Default: Motorhomes)	
	Tank Filler	Not Fitted	Sets if a tank filler function is available, to allow the internal tank to be automatically filled from an external water container.
		Fitted	
	Drain Valves	None	** Not available on MC100 **
		Fresh	
		Waste	
		Both	
ACCESSORY	Gas Control	Not Fitted	** Not available on MC100 **
		Fitted	
	Solar CANBUS	PSU	Selects solar regulator integrated into PSU.
		CAN	Selects CAN-Bus enabled solar regulator, which provides additional information on the control panel screen

Modular Control System (with EC940 Control Panel)

		Not Fitted	Disables solar regulator feature
	AC/DC CANBUS	Not Fitted	** For future use **
		Fitted	Sets if a CAN-Bus enabled AC-DC charger is fitted, which provides additional information on the control panel screen
	DC/DC CANBUS	Not Fitted	** For future use **
		Fitted	Sets if a CAN-Bus enabled DC-DC charger is fitted, which provides additional information on the control panel screen
	Water CANBUS	None	Sets if a CAN-Bus enabled ultrasonic water sensor is fitted to Fresh, Waste or Both tanks, to provide more accurate water level information on the control panel screen
		Fresh	
		Waste	
		Both	
	Webasto Heater	Not Fitted	** For future use **
		Fitted	Sets if a Webasto heater is fitted to allow operation from the control panel screen
CALIBRATE	Calibrate Ammeter	<< Press >>	Use this if you need to re-calibrate the battery ammeter. Firstly, turn off the mains battery charger at the PSU (green button). Press the '>' button to start the calibration. Please note that the lights will go out during the calibration process.
	CANBUS Fresh Sensor	< Press ??cm >	Used to re-calibrate a CAN-Bus enabled fresh water sensor. Ensure there is no water in the tank before pressing the '>' button. After successful calibration the tank depth will be displayed.
	CANBUS Waste Sensor	< Press ??cm >	Used to re-calibrate a CAN-Bus enabled waste water sensor. Ensure there is no water in the tank before pressing the '>' button. After successful calibration the tank depth will be displayed.
	Lithium Address	Set	Used to swap the communication address of a lithium battery when fitting a twin battery system. Ensure <u>only</u> the battery to be changed is connected to CAN-Bus then select 'Set' and press the '>' key to enter the setup screen.