

Stinger 300/310 Interface Wiring

Kit part WB2015 / drg 72023-09A

13 Pin or 12N
Connector
feed from Car

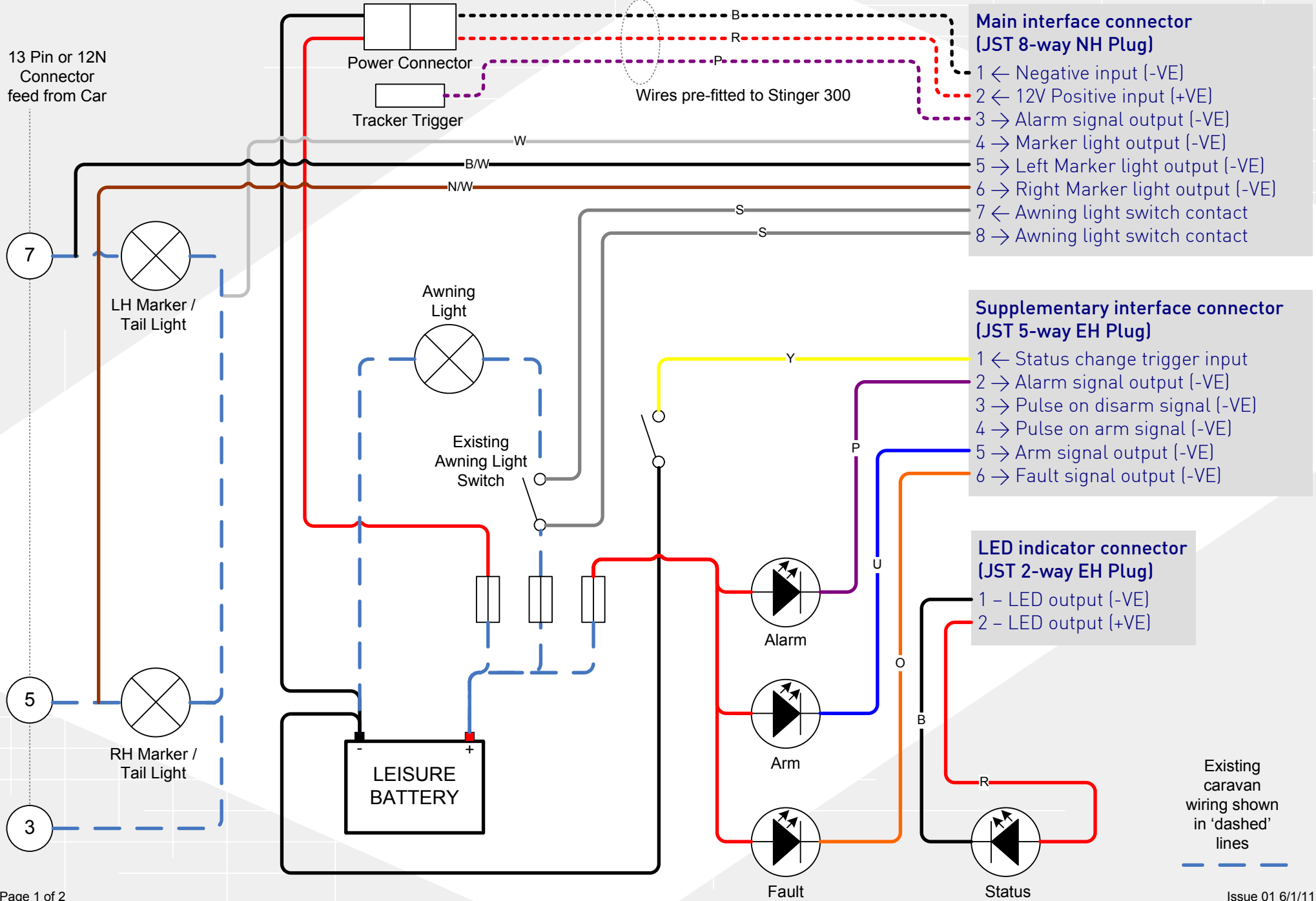

Existing
caravan
wiring shown
in 'dashed'
lines

Stinger 300/310 Interface Wiring

Please note this kit of parts and related information is intended for competent persons. If you are not sure of what you are doing, please STOP as you may damage the alarm system or components within your caravan.

Installation notes

- Before adding any wiring please disconnect the alarm from the 12V supply and turn the internal battery off (as follows). Open the unit case by removing the two top screws and the cross fixing bolt (requires 10mm spanner). You can now lift the lid from the alarm, where you will see a small battery switch. Please switch to the off (0) position. After installation of any wiring, please reverse the above procedure to turn the alarm back on again.
- Marker light flashing. Use the W, B/W and N/W cables which should be inserted into the main interface connector as per the diagram. The connector is already fitted within the alarm with some wires already in place. These connection cables can now be extended to connect to the appropriate road light connections. B/W and N/W connect to the positive side of the left and right marker lights. The W cable connects to the road light negative.
- Awning light control. Use the two S cables which should be inserted into the main interface connector as per the diagram. These connection cables can now be extended to connect to either side of the awning light switch. The alarm will work in parallel with the awning switch so please ensure the awning switch is in the off position to allow control by the alarm.
- External trigger input. Use the Y cable which is already fitted to the supplementary interface connector. This can then be extended and connected to a switch or other device. As this input looks for a change of state it can use a normally open or closed switch.
- Status Indicator. Use the R and B cables which are already fitted to the LED indicator connector. These cables can be extended and connected to a standard LED (typically 2.2V).
- State indicators. Use the P, U and O cables to connect to any required state indicators. The Alarm output will become negative when the alarm siren is active. The Arm output will become negative when the alarm is armed. The Fault output will become negative when the alarm has identified a fault (such as a low battery). These indicators should use an LED suitable for connection to 12V and should be supplied from an appropriately fused supply.

Example



Y/U Yellow cable with Blue stripe

Kit contents

- 11 x wires of differing colours with terminal fitted to one end
- 1 x 6-way JST EH connector (for supplementary connector)
- 1 x 2-way JST EH connector (for LED status connector)
- This instruction sheet

12v Cable Colours

B	BLACK
N	BROWN
R	RED
O	ORANGE
Y	YELLOW
G	GREEN
U	BLUE
P	PURPLE
S	SLATE GREY
W	WHITE
K	PINK