

Overview

This DC-DC converter can boost the supply voltage from the vehicle battery, in order to provide 12 volt fridge circuits with a higher and more stable supply voltage. This helps the fridge to operate more effectively during driving and run cooler.

Installation

The booster should be installed horizontally or vertically as close to the fridge as possible. During operation the booster will become warm, so ensure there is at least 10cm clear around the unit at all times.

Wiring & Fusing

When fitting, try to keep cabling runs as short as possible and do not underrate, as this will lead to excessive voltage losses and reduced performance. Under full load the booster will draw a large amount of current and the input side will typically draw larger currents than the output by a factor of up to 25%. Please refer to the table to select a suitable wiring gauge, length and recommended fuse rating.

Cable	Up to 3m	Up to 6m	Up to 10m	Fuse
from Vehicle battery	3mm ² 13AWG	4mm ² 12AWG	6mm ² 10AWG	25A
to Fridge	2.5mm ² 14AWG	3mm ² 13AWG	4mm ² 12AWG	20A

Connections

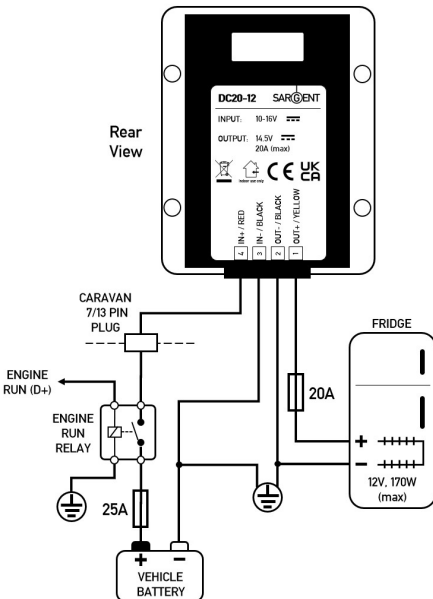

Engine Running Relay

To avoid draining the vehicle battery whilst parked, a relay should be fitted, as shown in the diagram. This will ensure 12V power is only supplied to the fridge once the vehicles engine is running.

Operation

Once fitted the unit will operate automatically to boost power from the vehicle battery into a suitable voltage to power the fridge during driving.

Specification

Model	DC20-12
Power	290W (max)
Input voltage range	10 - 16V
Output voltage (boost)	14.5V
Output current	20A (max)
Standby current	20mA (max)
Weight	0.5kg
Dimensions	100 x 78 x 39mm
Operating temperature	-20 - 50°C

SARGENT
wired for innovation

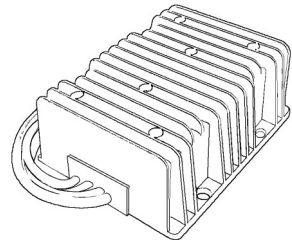

DC-DC Converter
Installation & User Instructions
DC20-12

SARGENT

Sargent Electrical Services Ltd

Unit 39, Tokenspire Business Park, Beverley,

East Yorks, HU17 0TB, UK

Phone: +44(0)1482 881655

Fax: +44(0)1482 678987

Email: support@sargentltd.co.uk

Tech Support: +44(0)1482 678981



H003